



## Technical data sheet TDS0065

### DUAL PREMIER INFRARED SENSOR FOR HYDROCARBONS and CARBON DIOXIDE Certified versions types MSH-DP-HC/CO<sub>2</sub> and MSHia-DP-HC/CO<sub>2</sub>



Great Britain	Patent Numbers
Europe	GB 2 401 432 & GB 2 403 291
France	EP 1544603 & EP 1818667-Pending
Germany	EP [ FR ] 1544603
Italy	EP [ DE ] 1544603
Switzerland	EP [ I ] 11544603
USA	EP [ CH ] 1544603
	7, 244, 939
	Other World Patents Pending

#### FEATURES

- ★ Combines all the features of the hydrocarbon and carbon dioxide Premier sensors, enabling the measurement of two different gases with one sensor.
- ★ No increase in physical size or power consumption when compared with a single gas Premier sensor. Ideal for portable, battery powered instruments.
- ★ Contains all the necessary optics, electronics and firmware to provide THREE linearised, temperature-compensated measurements:  
Methane, propane and carbon dioxide
- ★ Digital output for direct interface to host circuitry.
- ★ The hydrocarbon channel can be used to measure methane from 0 to 100% volume with an auto-ranging feature that provides the optimum resolution in both the % LEL range and the % volume range. Has equal performance to a 0-5% volume methane sensor AND a 0-100% volume methane sensor.
- ★ The storage of multiple calibration, temperature compensation and linearisation data enables simultaneous readings from the hydrocarbon channel for high resolution methane AND a 0-2% volume propane.
- ★ All sensor types are user configurable using configuration equipment available from Dynamant.
- ★ Fast track route for original equipment manufacturers to introduce the latest infrared



#### Dynamant Limited

Premier House · The Village · South Normanton · Derbyshire · DE55 2DS · UK.  
Tel: 44 (0)1773 864580 · Fax: 44 (0)1773 864599  
email: [sales@dynamant.com](mailto:sales@dynamant.com) · [www.dynamant.com](http://www.dynamant.com)

## DESCRIPTION

Dynamant infrared sensors operate by using the NDIR principle to monitor the presence of target gas. The sensor contains a long life tungsten filament infrared light source, an optical cavity into which gas diffuses, temperature compensated pyroelectric infrared detectors, an integral semiconductor temperature sensor and electronics to process the signals from the pyroelectric detector .

The sensor uses a digital output for direct communications with instrument electronics. The digital output is a UART format comprising 8 data bits, 1 stop bit and no parity. Refer to specification for available baud rates.

## **Hydrocarbon Response Characteristics**

The Premier range of hydrocarbon infrared gas sensors are calibrated to provide an output signal linearised for a specific gas type and concentration during manufacture.

However, the sensor will also respond to a range of other hydrocarbon gases. The following graphs show the relative response of a methane sensor, and a propane sensor, to some of the common hydrocarbons.

These characteristics can be used as a guide to setting up the associated instrument alarm levels.

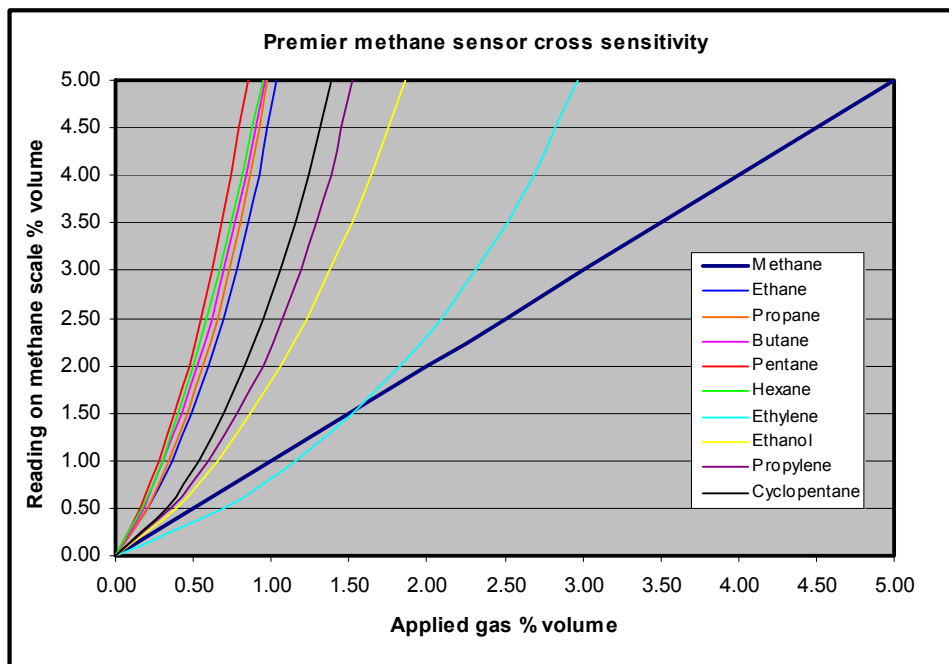

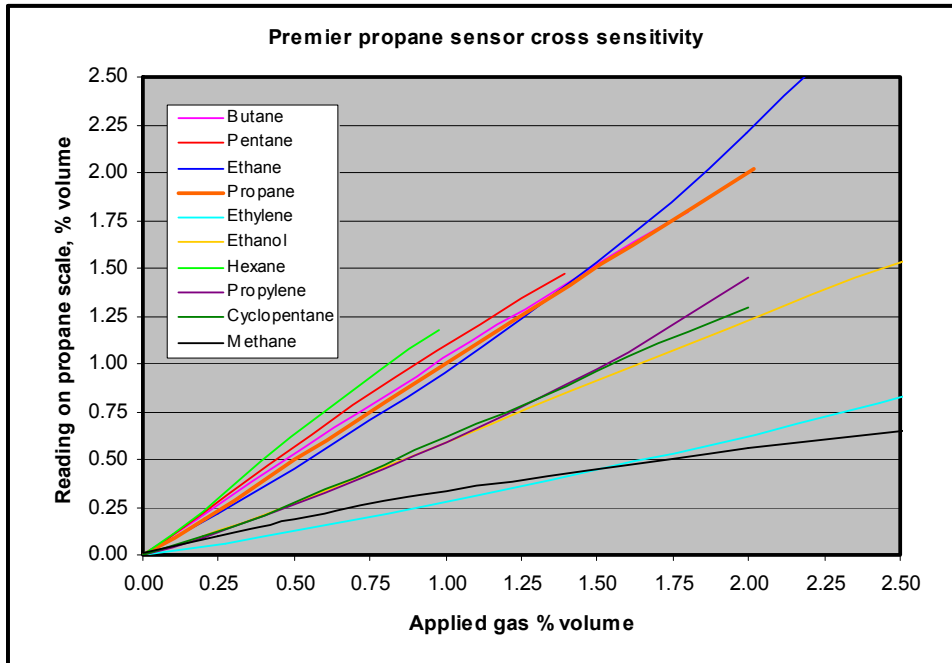

Note – Refer to data sheet TDS0050 for additional cross reference data

### Hydrocarbon Temperature Compensation

The Premier sensor is temperature compensated over the range of -20°C to +50°C. The output variation is  $\pm 2\%$  FSD or  $\pm 10\%$  of the reading up to 50% FSD and  $\pm 15\%$  of the reading from 50% to 100% FSD, which ever is greater.

The following graph is based on the hydrocarbon sensor being characterised for methane.

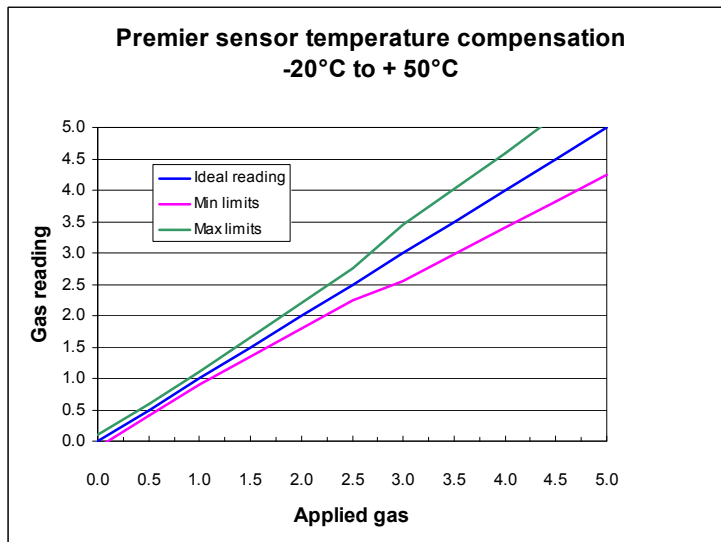

## Hydrocarbon Linearity

The Premier sensor linearity at ambient temperature is  $\pm 2\%$  FSD or  $\pm 10\%$  of the reading which ever is greater.

The following graph is based on the hydrocarbon sensor being characterised for methane, data based on 24 sensors.

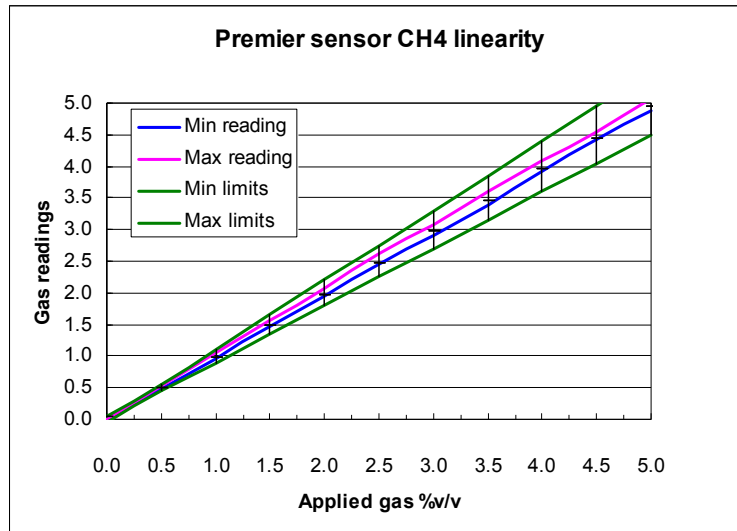

## Carbon dioxide Temperature Compensation

The Premier sensor is temperature compensated over the range of  $-20^{\circ}\text{C}$  to  $+50^{\circ}\text{C}$ . The output variation is  $\pm 0.1\%$  v/v or  $\pm 10\%$  of the reading up to 50% FSD and  $\pm 15\%$  of the reading from 50% to 100% FSD, which ever is greater.

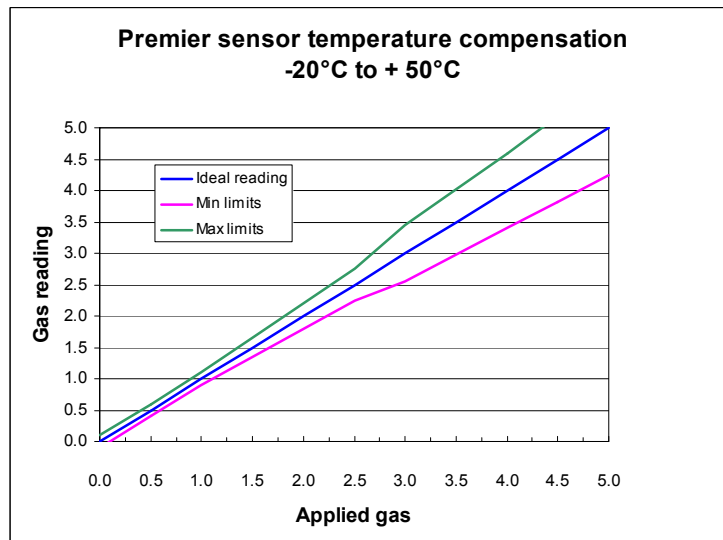

## Carbon dioxide Linearity

The Premier sensor linearity at ambient temperature is  $\pm 2\%$  FSD or  $\pm 10\%$  of the reading which ever is greater.

The following graph is based on the 0-5% v/v sensor, data for 24 sensors.

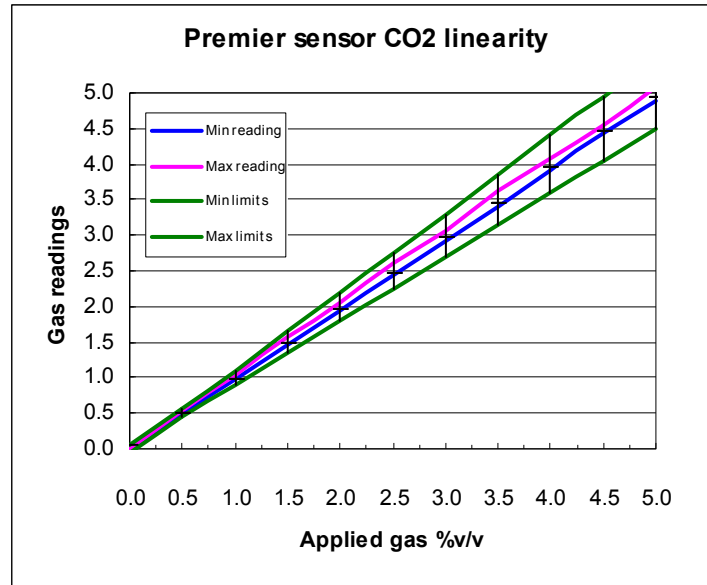

## Calibration options

Dynamant recommend a maximum interval of 12 months between calibration checks. A small amount of zero drift can be accommodated by re-zeroing the gas detector against the sensor. The degree of drift that is acceptable should be determined by the user. Note that the subsequent change in gas reading will be greater than the change in zero reading. If the sensor requires either a "Zero" or "Span" adjustment, there are three methods that can be used:

- 1) By using the "Premier Configuration Unit"  
When used in conjunction with dedicated PC software, this device uses the data communication pins on the sensor to provide a means of calibration. Refer to data sheet TDS0043 for additional information.
- 2) By using the data communications pins and software written in accordance with the protocol supplied by Dynamant.

## Sensor warm-up time

When power is first applied to the sensor, the voltage at the output pin is held at a pre-determined level. The default setting for this start-up value is the "zero gas" value. This condition is maintained for a default "warm-up" time of 15 seconds, after this time the output voltage represents the calculated gas value. Sensors can take up to 1 minute to indicate the correct gas reading.

Note: the sensor can calculate any reading from -100% FSD to +200% FSD in the first minute. The output value that is read using the communications pins is always held at zero during the "warm-up" time.

The duration of the “warm-up” time can be pre-programmed to alternative values at the time of ordering sensors.

### **Temperature transients and gas flow rates.**

The Premier sensor employs a pyroelectric detector, the output from which can be disrupted by sudden changes in temperature. If there is an excessive change in the ambient temperature, gas sample temperature or flow rate, then the output signal will be momentarily frozen. Correct operation is restored when the effects of the transient have settled. Rates of change in the ambient temperature should be restricted to 2°C/minute and gas flow rates kept below 600 cc/minute.

### **Power supply considerations**

The sensor power supply rise time must be less than 50 mS to ensure correct operation. Operation outside the range of 3 – 5 V dc will result in either fault indication, or the sensor will not function correctly.

### **Sensor over-range condition**

The sensor will continue to provide a reading up to 200% of the full scale value; at this point the reading is clamped, regardless of any further increase in detected gas level. The linearity of the reading is only guaranteed up to the full scale for the sensor; the over-range condition should therefore be determined and indicated by the host instrument.

### **Sensor fault indication**

The sensor constantly performs checks on the internal memory contents, the incoming supply voltage and the analogue signal values. These checks are used to ensure that the sensor is operating within its correct parameters, and that no internal faults have developed.

If a fault condition is detected, the output reading is set to the -100% full scale value.

### **Digital interface**

The digital communication pins “RX” and “TX” operate at a 2.8V logic level. When interfacing to external circuitry that uses a higher voltage level it is necessary to limit the current that can flow. The external voltage level should be 5V maximum and a 3K3 resistor should be used in series with each communication pin.

The Rx and Tx voltage limits are as follows:

RX - VIH: Input ‘High’ minimum voltage -  $0.8 V_{DD} = 2.24V$

RX - VIL: Input ‘Low’ maximum voltage -  $0.2 V_{DD} = 0.56V$

TX - VOH: Output ‘High’ minimum voltage -  $V_{DD} - 0.7 = 2.1$

TX - VOL: Output ‘Low’ maximum voltage - 0.6V

The digital output is a UART format comprising 8 data bits, 1 stop bit and no parity. Refer to specification for available baud rates. Contact Dynament Ltd for protocol details.

## CERTIFICATION DETAILS

CERTIFICATION DETAILS		
<b>European ATEX Certification</b>	<b>Sensor type MSH-P</b>	<b>Sensor type MSHia-P</b>
<b>Approval body</b>	SIRA	
<b>Certificate Number</b>	SIRA 04ATEX1357U	
<b>Test Standards</b>	EN60079-0:2009, EN60079-1:2007, EN60079-11:2007, EN60079-26:2007	
<b>Certification Codes</b>	I M2 Ex d I Mb II 2 G Ex d IIC Gb	I M1 Ex d+ia I Ma II 2 G Ex d IIC Gb
<b>Input parameters</b>	0.8W max, 30V max. (See footnote)	Ui=6V dc, Pi=0.8W (See footnote)
<b>Operating temperature</b>	-20°C to +60°C (See footnote)	
<b>International IECEx Certification</b>	<b>Sensor type MSH-P</b>	<b>Sensor type MSHia-P</b>
<b>Approval body</b>	SIRA	
<b>Certificate Number</b>	IECEX SIR 05.0053U	
<b>Test Standards</b>	IEC 60079-0:2007-10, Edition 5 IEC60079-1:2007-4, Edition 6 EN60079-26:2006 Edition 2	
<b>Certification Codes</b>	Ex d I and/or Ex d IIC	Ma Ex d+ia I and/or Gb Ex d IIC
<b>Input parameters</b>	0.8W max, 30V max.	Ui=6V dc, Pi=0.8W
<b>Operating temperature</b>	-20°C to +60°C (See footnote)	
<b>North American Certification</b>	<b>Sensor type MSH-P</b>	<b>Sensor type MSHia-P</b>
<b>Approval body</b>	Underwriters Laboratory Inc.	Underwriters Laboratory Inc.
<b>File Reference</b>	E336365	E336365
<b>Test Standards</b>	UL 60079 – 0, 4 <sup>th</sup> Edition UL 60079 - 1, 6 <sup>th</sup> Edition CAN/CSA-C22.2 No. 60079-0-1-7 CAN/CSA-C22.2 No. 60079-1 part 1, 1 <sup>st</sup> Edition	UL913 7 <sup>th</sup> , Edition UL 60079 – 0, 4 <sup>th</sup> Edition UL 60079 – 11, 2 <sup>nd</sup> , Edition CAN/CSA-C22.2 No. 157-92
<b>Hazardous Locations</b>	Class 1, Zone 1, AEx d IIC and Ex d IIC Hazardous Locations	Class I, II, III, Division 1 Class 1, Zone 0, AEx ia IIC, T4 with 60°C ambient
<b>Input/Entity parameters</b>	0.8W max, 30V max.	Ui=6V dc, Pi=0.8W, Ci=4.105µF, Li=0 mH
<b>Input parameters are defined for certification purposes only, refer to the “Specification” table for the sensor operating voltage and temperature range.</b>		

## GENERAL SPECIFICATION

<b>Operating Voltage Range:</b>	3.0 – 5.0 V d.c.
<b>Operating Current:</b>	Constant current operation, current range 75 – 85mA
<b>Operating temperature range:</b>	-20°C to +50°C (-4°F to 122°F)
<b>Warm up time:</b>	To final zero ± 2% of full scale: 1 minute @ 20°C (68°F) ambient
<b>Storage temperature range:</b>	-20°C to +50°C (-4°F to 122°F)
<b>Humidity range:</b>	0 to 95% RH non-condensing.
<b>Digital signal format:</b>	8 data bits, 1 stop bit, no parity. 2.8V logic level
<b>Standard baud rates:</b>	38,400, 19,200, 9600
<b>User configurable parameters:</b>	Full-scale value, resolution, Sensor 'zero' function Sensor 'span' function
<b>MTBF:</b>	> 5 years
<b>Weight :</b>	15 grams

## HYDROCARBON CHANNEL SPECIFICATION

<b>Methane measuring range:</b>	0 – 100% volume
<b>Hydrocarbon measuring range</b>	0 – 100% LEL equivalent
<b>Resolution: (Methane calibration)</b>	0.01% vol. methane for readings up to 10% methane, 0.1% vol. methane for readings from 10% vol. up to 100% vol.
<b>Accuracy:</b>	± 2% of full scale @ 20°C (68°F), 1 bar pressure, applied gas 2.5% volume methane.
<b>Response Time T<sub>90</sub>:</b>	<30s @ 20°C (68°F) ambient
<b>Zero Repeatability:</b>	± 1% of full scale @ 20°C (68°F) ambient
<b>Span Repeatability:</b>	± 2% of full scale @ 20°C (68°F) ambient
<b>Long term zero drift:</b>	± 1% of full scale per month @20°C (68°F) ambient, (max ± 3% of full scale per year)
<b>Temperature performance:</b> <small>* May not be applicable when using gas cross-reference factors</small>	± 10% of reading up to 50% of full scale, ± 15% of reading from 50% to 100% of full scale, or 2% of full scale whichever is greater over the range -20°C to +50°C (-4°F to 122°F)

## CARBON DIOXIDE CHANNEL SPECIFICATION

<b>Measuring ranges:</b>	0 - 5%, 0-4%, 0-3%, 0-2%, 0-1% volume CO <sub>2</sub>
<b>Resolution:</b>	0.01% volume CO <sub>2</sub> .
<b>Accuracy:</b>	± 2% of full scale @ 20°C (68°F), 1 bar pressure, applied gas 2.5% volume CO <sub>2</sub> .
<b>Response Time T<sub>90</sub>:</b>	<30s @ 20°C (68°F) ambient
<b>Zero Repeatability:</b>	± 500ppm @ 20°C (68°F) ambient
<b>Span Repeatability:</b>	± 500ppm @ 20°C (68°F) ambient
<b>Long term zero drift:</b>	± 500ppm / month @ 20°C (68°F) ambient
<b>Operating temperature range:</b>	-20°C to +50°C (-4°F to 122°F)
<b>Temperature performance:</b>	± 10% of reading up to 50% of full scale and ± 15% of reading from 50% to 100% of full scale over the range -20°C to +50°C (-4°F to 122°F)

## MECHANICAL DETAIL

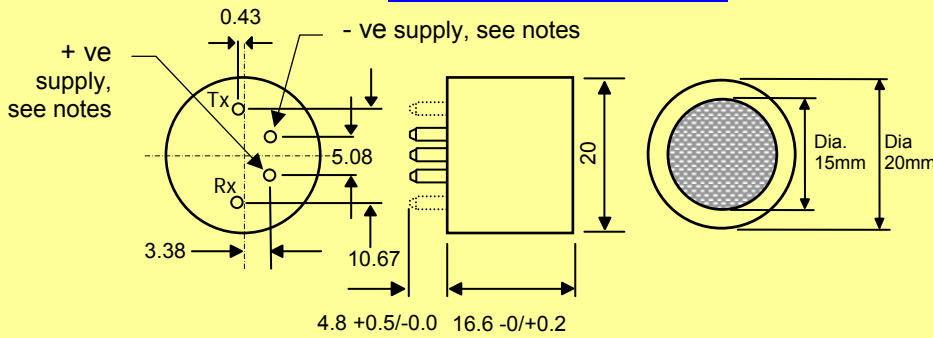

## NOTES

1. TOLERANCE: +/- 0.15 UNLESS OTHERWISE STATED.
2. RECOMMENDED PCB SOCKET WEARNES CAMBION LTD CODE: 450-3326-01-06-00.
3. **USE ANTI-STATIC PRECAUTIONS WHEN HANDLING**
4. **DO NOT CUT PINS**
5. **DO NOT SOLDER DIRECTLY TO PINS**
6. THE LABELLING ADDS UP TO 0.2 TO THE OUTER DIAMETER, AND UP TO 0.2 TO THE OVERALL HEIGHT

All dimensions are in millimetres. Pins viewed from underside  
 Diameter of pins = 1.5 +/- 0.05  
 Tx & Rx communication connections are available as either pads or pins

**NOTE – The above pin configuration is shown for the POSITIVE version of the sensor. The NEGATIVE version has the +ve and –ve supply pin positions exchanged. See ordering details.**

### Ordering Details

In order to completely specify the type of sensor that is required, the customer needs to provide the following information:-

- An Order Code (see below) that specifies the sensors' basic physical and electrical characteristics.
- The sensor configuration requirements.

## EXAMPLE OF ORDER CODES

**MSH – DP / HC / CO2 / P / F**

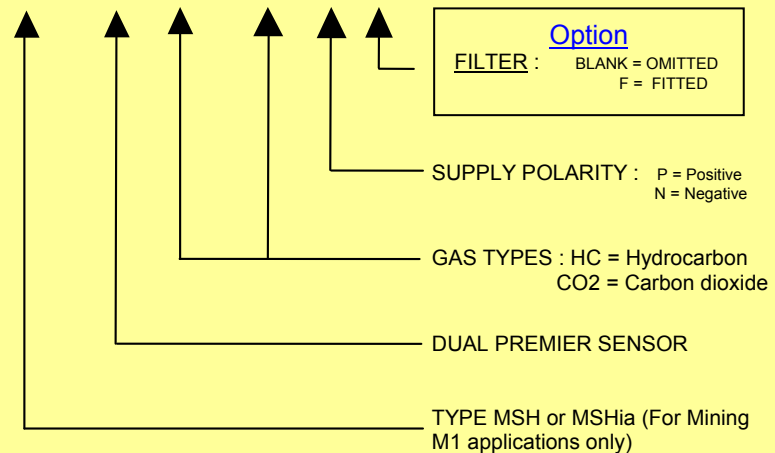

### Available sensor options:

F = Replaceable, self adhesive microporous PTFE filter

## CONFIGURATION OPTIONS (To be stated on customer order in addition to the Order Code)

1. Communication speed – 38,400 baud (default), specify alternative rate if required.

## Warranty information

All Dynament Premier sensors carry a **five** year warranty against defects in materials and workmanship. The warranty is invalidated if the sensors are used under conditions other than those specified in this data sheet.

Particular attention should be paid to the following criteria:

- **Observe the correct supply polarity**
- **Do not exceed the maximum rated supply voltage of 5V**
- **Do not solder directly to the sensor pins**
- **Do not expose the sensor to corrosive gases such as hydrogen sulphide**
- **Do not allow condensation to take place within the sensor**

Dynament reserve the right to alter technical specifications, without prior notice, when it is appropriate to implement a technical enhancement that leads to improved performance. Should any changes be required that could affect the customer's use of the product, Dynament will endeavour to contact customers directly to inform them of the changes.